

# AVN 250 XC – AVN 700 XC

## Pipe Jacking

### Special Features

- All machines for non-accessible sections.
- Designed for soft ground, mixed ground and hard rock conditions by use of different cutting wheels (full face excavation).
- Highly reliable steering operation due to inductive measuring system.
- Different (variable) flushing modes / jet systems to suit different ground conditions.
- High pressure water system for operation in cohesive soil.
- Providing highly effective cone crusher.
- Equipped with heavy duty long-life main bearing and high torque peripheral drive.
- Hydraulic power pack in control container.
- Completely remote-controlled.
- All machines compatible to U.N.S. Guidance System.

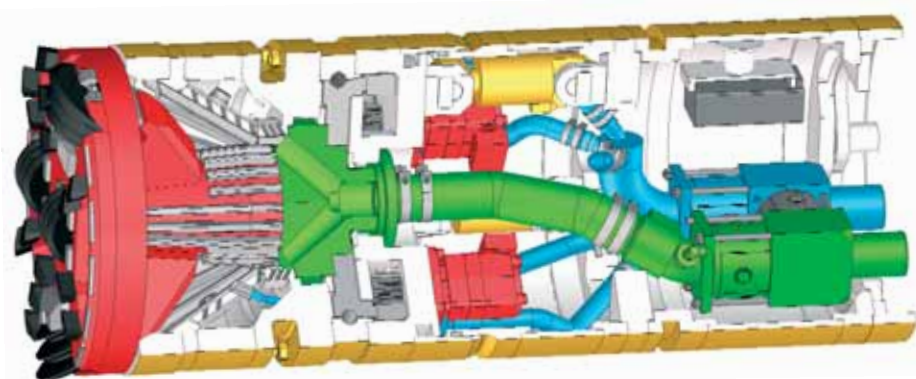

Technical Data			AVN250XC		AVN300XC		AVN400XC		AVN500XC		AVN600XC		AVN700XC	
			Std*	Ext*	Std	Ext	Std	Ext	Std	Ext	Std	Ext	Std	Ext
<b>1. Articulated Shield</b>														
Outer diameter	mm		368	410	410	565	565	665	665	780	780	875	875	975
Pipe OD	mm		360	400	400	550	550	650	650	760	760	860	860	960
Pipe ID	mm		250	300	300	400	400	500	500	600	600	700	700	800
<b>Main drive</b>														
Max. torque	kNm		5.9		9.4		13.4		22.2		33.5		40.1	
Revolution	LH / RH rpm		0-44		0-27		0-19		0-15		0-13		0-11	
Rated Power	kW		45		45		45		45		45		55	
Roll correction			✓		✓		✓		✓		✓		✓	
<b>Steering</b>														
Steering cylinders			3		3		3		3		3		3	
Force per cyl. / oil pressure	kN/bar		116/500		245/500		245/500		311/500		311/500		383/500	
Stroke per cyl.	mm		10		15		15		25		25		30	
<b>Control</b>														
Computer data logging system			✓		✓		✓		✓		✓		✓	
Fuzzy control (automatic steering)			opt.		opt.		opt.		opt.		opt.		opt.	
Fully visualized process control			✓		✓		✓		✓		✓		✓	
Active roll protection (el.-hydr.)			✓		✓		✓		✓		✓		✓	
Suitability U.N.S.: ELS			✓		✓		✓		✓		✓		✓	
ELS-HWL			-		-		✓		✓		✓		✓	
GNS-P			-		-		-		✓		✓		✓	
<b>2. Machine Can</b>														
Lubrication System			✓		✓		✓		✓		✓		✓	
<b>3. General Information</b>														
Pipe jacking			✓		✓		✓		✓		✓		✓	
Drive length (recommended)	m		80		100		100		120		140		140	
Waterproofness	bar		3		3		3		3		3		3	
Telescopic and interjacking station			-		-		-		-		opt.		opt.	
Slurry line diam.	mm		55		55		80		100		100		100	
High pressure water system			✓		✓		✓		✓		✓		✓	

All measures and data represent the main feasibility of the machines. Individual solutions are possible. Errors excepted.

\* Std = standard; Ext = extension kit

# Machine dimensions

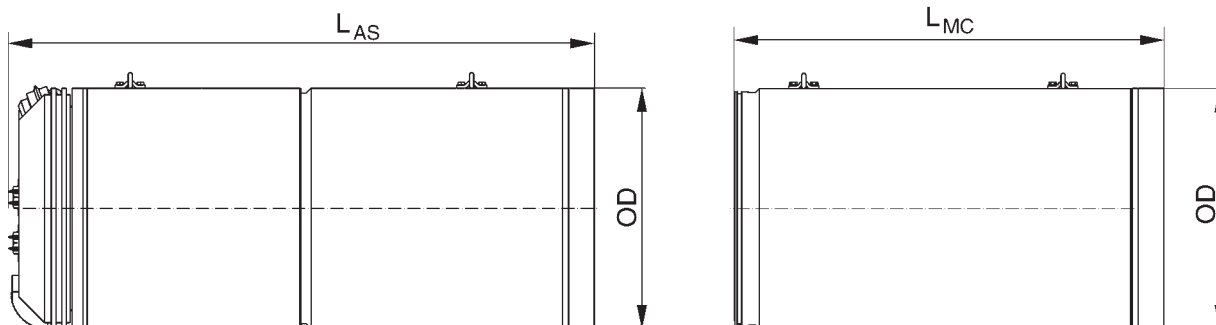

			AVN250XC	AVN300XC	AVN400XC	AVN500XC	AVN600XC	AVN700XC
Outer diameter	OD	mm	368	410	565	665	780	875
Length artic. shield	L <sub>AS</sub>	mm	1 400	1 450	1 450	2 150	2 100	2 500
Length machine can	L <sub>MC</sub>	mm	1 200	1 200	1 200	2 000	2 000	2 000
Max. single weight	W	kg	850	950	1 100	3 000	3 800	4 400

# Shaft dimensions

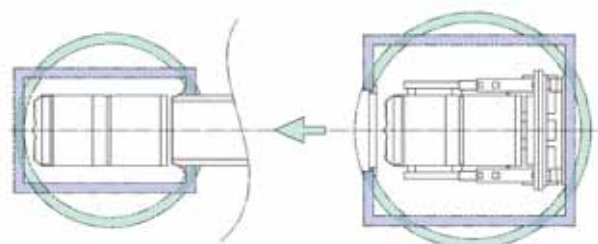

			AVN250XC	AVN300XC	AVN400XC	AVN500XC	AVN600XC	AVN700XC
Launch shaft Compact jacking rig	Pipe length	Shaft size	Shaft size	Shaft size	Shaft size	Shaft size	Shaft size	Shaft size
		1 000 mm	Ø = 2m	Ø = 2m	Ø = 2.5m	Ø = 3m	Ø = 3m	Ø = 3m
		2 000 mm	Ø = 3m	Ø = 3m	Ø = 3m	Ø = 3m	Ø = 3m	Ø = 3.2m
Reception shaft	L <sub>AS</sub>	1 400mm	1 450mm	1 450mm	2 150mm	2 100mm	2 500mm	
		Circular	Ø = 1.5m	Ø = 1.6m	Ø = 1.6m	Ø = 2.3m	Ø = 2.4m	Ø = 2.5m
		Rectangular	1.5m x 1.0m	1.6m x 1.0m	1.6m x 1.0m	2.3m x 1.2m	2.4m x 1.4m	2.5m x 1.5m

All dimensions according to 10m shaft depth.

Machine type description e.g. AVN <sup>1)</sup> 1800 <sup>2)</sup> T <sup>3)</sup> B <sup>4)</sup>			
<sup>1)</sup> Machine type	<sup>2)</sup> ID of jacking pipe	<sup>3)</sup> Access to cutting wheel	<sup>4)</sup> Type of container, power transfer from container to machine
		X = no access	B = electric cable to machine, power pack in machine
		T = central door	C = hydraulic drive from container directly into machine
		A = door above main drive or in top of pressure wall	E = electric cable from container directly into machine
			H = medium voltage supply to machine (> 1000V)

Herrenknecht AG  
 D-77963 Schwanau, Germany  
 Tel. +49 (7824) 302 923  
 Fax +49 (7824) 302 364  
 utility@herrenknecht.com  
 www.herrenknecht.com

